

Mining and Processing Industry:

Split Bearings/ Split Costs

FAG



Split Bearings – Split Costs

Time-Saving Bearing Replacement in Hard to Reach Locations

Complicated replacement procedures such as pulling gears and couplings, dismounting drives, or stripping line shafting are major causes of equipment downtime. In applications for the mining and processing industry, where the replacement of a solid spherical roller bearing would require such procedures, the FAG split spherical roller bearing can be used instead.

Mounting Costs Reduced

Mounting of split spherical roller bearings leads to the reduction of machinery and plant downtime resulting in significantly lower mounting costs. In many cases, split spherical roller bearings can also save considerable costs in new construction since they simplify the assembly process and facilitate mounting.

Applications

- Bucket wheel excavators and reclaimers
- Winch drums and rope sheaves
- Screw conveyors
- Bucket elevators and conveying belts
- Mixers and stirrers
- Mills and crushers
- Sinter plants and rotary kilns
- Fans and blowers
- Dedusting equipment
- Drive and line shafts

In general „classic“ applications of split spherical roller bearings range from shafts supported by several bearings to bearing locations with restricted access.

Replacement Bearings for Spherical Roller Bearings with Adapter Sleeves

The outside diameter, outer ring width and shaft seat diameter are identical to the dimensions of the standard

spherical roller bearings, therefore FAG split spherical roller bearings can easily be installed instead of solid spherical roller bearings with an adapter sleeve.

Mounting in Split Pillow Block Housings

FAG split spherical roller bearings can be mounted into FAG split pillow block housings without requiring any further machining of the housing. The same applies to housings from other manufacturers, provided that the internal dimensions are identical.

Proven Design

The internal design of split spherical roller bearings is identical to the proven high capacity FAG E-design spherical roller bearing. This maximum load carrying capacity results in longer service life and proven FAG quality.

Metric or Inch Dimensions

The wide range of FAG split spherical roller bearings include standard series like 222, 230 and 231 and starts from 55 mm and 2 3/16 inch. For dimensions and technical data see FAG Publication No. WL 43 165. Information on other designs will be supplied upon request.

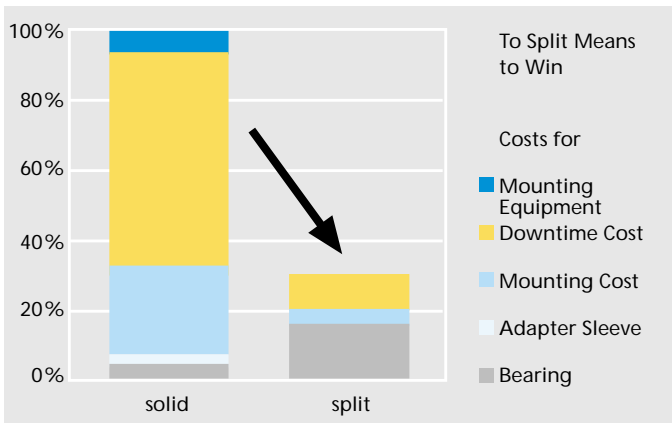

Simple Dismounting and Mounting lead to enormous cost reduction.





Split Bearings Pay Off

| Typical Steps (e.g. Blower) | Solid Bearing | Split Bearing |
|---|---------------|---------------|
| Disconnect drive (gear box, V-belts, E/motor) | ● | |
| Remove coupling halves, pulleys, sprockets .. | ● | |
| Support impeller/shaft mass | | ● |
| Remove housing cap | ● | ● |
| Lift impeller/shaft assembly from housings | ● | |
| Remove housing base | ● | |
| Remove and replace bearings | ● | ● |
| Mount assembly in housings | ● | |
| Align housings base with shaft | ● | |
| Secure housing base to foundation | ● | |
| Secure housing cap | ● | ● |
| Re-install drive components | ● | |
| Re-connect and re-align drive unit | ● | |

● = Required replacement procedure

Compare!

| | Solid Bearing | Split Bearing |
|--|---------------|---------------|
| Downtime cost (disruption hours x value of production output per hour) | | |
| Cost of lifting equipment (e.g. crane rental) | | |
| Cost of special mounting tools (e.g. hydraulic nut) | | |
| Labour cost for mounting (man hours x hourly wage) | | |
| Cost of replacement bearing (split or unsplit with adapter sleeve) | | |
| Cost of alignment equipment | | |
| Labour cost for alignment (man hours x hourly wage) | | |
| Total Cost for Bearing Replacement | | |
| Cost Savings by Using a FAG Split Spherical Roller Bearing | | |

Please send me:

- Publication „FAG Split Spherical Roller Bearings“ (WL 43 165)
- Publication „Robust and long-lived Roller Bearings for Mining, Processing, and Construction“ (WL 21 107)
- Mouse Pad „Split Bearings – Split Costs“
- Please inform me detailed about cost reductions by usage of FAG split spherical roller bearings



Please complete, detach form and send to FAG Industrial Bearings or your FAG distributor

Fax ++ 49 (0) 97 21 / 91 47 96

Company/ Contact _____

Address _____

Phone / Fax / E-mail _____

Application _____

Bearing and sleeve to be replaced _____

Operating conditions _____

In Harsh Environments for Bearing Locations with Restricted Access for Maintenance and Assembly



Drive bearing arrangements of conveying and transport equipment



Bearing arrangements in crushers, mills and processing equipment



Main shaft bearing arrangements for bucket wheel excavators or reclaimers



Bearing arrangements in blowers, fans and dedusting equipment



Efficiency by Advanced Engineering

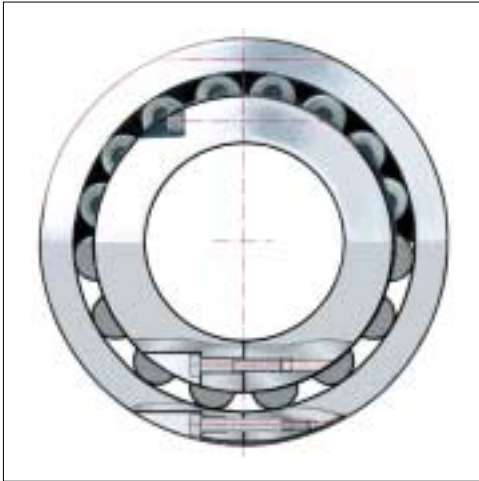

Split Spherical Roller Bearings come with glass-fibre reinforced Polyamide and Brass cages

The Downtime Solution

- Inner ring, outer ring and cage assemblies are split.
- Cylindrical bore provides for direct mounting onto shaft.
- Dimensions correspond to solid bearing and adapter sleeve.
- E-design provides an extended life.
- Fits into standard pillow block housings.
- High trust load capability.
- Dynamic compensation of misalignment.



For special applications split bearings with separate split clamping rings are available

Benefits

- Rapid bearing replacement.
- Very simple mounting procedure.
- No further dismounting of drive components.
- No further disassembling of shaftings.
- No need for further shaft alignment.
- Reduced downtime.
- Increased profitability.

FAG
Innovation in Motion

FAG Industrial Bearings Aktiengesellschaft

Postfach 1260 · D-97419 Schweinfurt · Germany

Tel. ++49 (0) 97 21 / 91 47 95 · Fax ++49 (0) 97 21 / 91 47 96

www.fag.de · E-mail: SplitBearings@fag.de