

## FAG SPECIAL SPHERICAL ROLLER BEARINGS FOR VIBRATING MACHINES

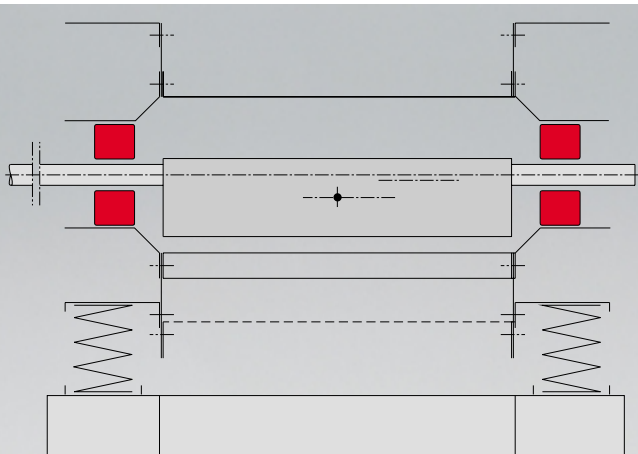
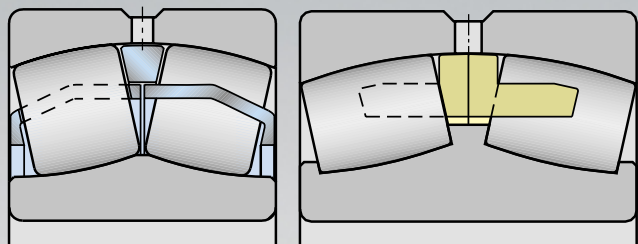

---

# **FAG Special Spherical Roller Bearings for Vibrating Machines**

**Publ. No. WL 21 100/3 EA**

## **FAG OEM und Handel AG**

A company of the FAG Kugelfischer Group

Postfach 1260 · D-97419 Schweinfurt

Telephone (0 97 21) 91 38 83 · Telefax (0 97 21) 91 39 58

[www.fag.de](http://www.fag.de)

# Contents

|          |   |           |
|----------|---|-----------|
| <b>1</b> | <b>FAG Spherical Roller Bearings for Vibratory Stressing</b>                              | <b>3</b>  |
| 1.1      | Operating conditions for bearings in vibrating machines                                   | 3         |
| 1.2      | Bearing series and basic designs  | 3         |
| 1.2.1    | Spherical roller bearings of series 223E  | 3         |
| 1.2.2    | Spherical roller bearings of series 223A  | 4         |
| 1.2.3    | Spherical roller bearings of series 233A  | 4         |
| 1.3      | Bearings with a tapered bore  | 4         |
| 1.4      | Bearings with a chromium-plated bore  | 4         |
| 1.5      | Specification T41A  | 4         |
| 1.5.1    | Tolerances of bearing bore and outside diameter   | 4         |
| 1.5.2    | Radial clearance groups, radial clearance reduction in bearings with a tapered bore       | 5         |
| 1.6      | Attainable radial acceleration  | 6         |
| 1.7      | Heat treatment  | 6         |
| <b>2</b> | <b>Dimensioning of the Bearings</b>   | <b>6</b>  |
| 2.1      | Two bearing screen with circle throw  | 6         |
| 2.2      | Two bearing screen with straight-line motion  | 8         |
| 2.3      | Four bearing screen   | 10        |
| 2.4      | Centrifugal force nomogram  | 11        |
| 2.5      | Load rating nomogram  | 12        |
| <b>3</b> | <b>Design Characteristics</b>   | <b>13</b> |
| 3.1      | Two bearing screen with circle throw (grease lubrication)                                 | 13        |
| 3.2      | Two bearing screen with circle throw (oil sump lubrication)                               | 14        |
| 3.3      | Two bearing screen with circle throw (oil circulation lubrication)                        | 15        |
| 3.4      | Two bearing screen with straight-line motion (oil splash lubrication)                     | 16        |
| 3.5      | Four bearing screen (grease lubrication)  | 17        |
| <b>4</b> | <b>Lubrication</b>  | <b>18</b> |
| 4.1      | Grease lubrication  | 18        |
| 4.2      | Oil lubrication   | 19        |
| 4.2.1    | Oil sump lubrication  | 19        |
| 4.2.2    | Oil circulation lubrication   | 21        |
| 4.3      | Recommended lubricants  | 22        |
| <b>5</b> | <b>Dimensional Tables of FAG Special Spherical Roller Bearings for Vibrating Machines</b> | <b>23</b> |
| 5.1      | Series 223E.T41A  | 23        |
| 5.2      | Series 223A.MA.T41A   | 24        |
| 5.3      | Series 233A(S).MA.T41A  | 24        |

# FAG Spherical Roller Bearings for Vibratory Stressing

Operating conditions · Bearing series and basic designs

## 1 FAG Spherical Roller Bearings for Vibratory Stressing

### 1.1 Operating conditions for bearings in vibrating machines

Vibrating screens, which are used for grading material, and other machines where vibratory stressing has to be accommodated, such as road rollers and saw frames, are among the most severe bearing mountings encountered in machinery construction.

The rolling bearings in the exciter-unit drives of these machines have to accommodate high loads, high speeds, accelerations and centrifugal forces. Often, adverse environmental conditions such as dirt and moisture have to be accommodated as well.

The special spherical roller bearings developed by FAG are designed for the operating conditions in vibrating machines and have proven their worth in field application.

Especially the cages of the rolling bearings are stressed by high radial accelerations. Under unfavourable conditions, axial accelerations may have to be accommodated as well.

The rotating imbalance generates a revolving shaft deflection and additional sliding motions within the bearings. As a result, the friction, and consequently the operating temperature of the bearings, increase. The special spherical roller bearings can compensate for the usual misalignments between inner ring and outer ring up to  $0.15^\circ$ . Where greater misalignments have to be accommodated, FAG Application Engineering should be consulted.

### 1.2 Bearing series and basic designs

The main dimensions of the FAG special spherical roller bearings for vibrating machines correspond to the dimensional series 23 and 33 (E DIN 616: 1995-01, ISO 15).

To accommodate the specific operating conditions found in vibrating machines FAG manufacture all the special spherical roller bearings described in this publication in accordance with specification T41A, see also section 1.5.

The highest load carrying capacity due to an optimized cross section utilization is provided by the advanced spherical roller bearings of series 223E. The bearings designed to accommodate vibratory stressing are available with bore diameters of up to 150 mm. They have outer ring riding, surface-hardened pressed steel window-type cages with a good form rigidity.

FAG bearings of dimensional series 223 with bore diameters of more than 150 mm are available as design A. The inner ring has three fixed lips. Two outer ring riding machined brass cage halves radially support the forces of gravity toward the outside.

Wider bearings of series 233A have a similar internal design as the bearings of series 223A. These bearings are used for applications where an extremely high load carrying capacity is required.

#### 1.2.1 Spherical roller bearings of series 223E

E-design FAG spherical roller bearings have no centre lip on their inner ring and excel by an extremely high load carrying capacity. This advantage is also offered by

the FAG special bearings for vibratory stressing of design 223E.T41A, fig. 1.

#### 1: New design 223E.T41A of special spherical roller bearings for vibrating machines (bore reference numbers 08 to 30)

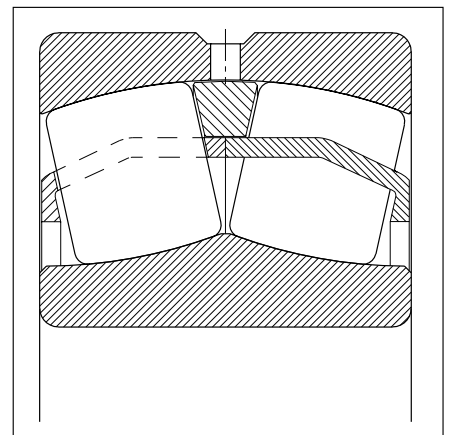

This is the new FAG standard design for bearings with bore diameters of 40 to 150 mm (bore reference numbers 08 to 30).

After extensive testing both on the test rig and in the field, the bearings of design 223E.T41A have proved to be extremely suitable for numerous field applications.

In the bearing, every roller row has its own outer ring riding window-type pressed steel cage half.

The cage halves are supported by the cage guiding ring in the outer ring. Depending on the bearing size, either a split or an unsplit guiding ring is used. All cage components have hardened surfaces.

# FAG Spherical Roller Bearings for Vibratory Stressing

Bearing series and basic designs · Bearings with a tapered bore · Bearings with a chromium-plated bore · Specification T41A

## 1.2.2 Spherical roller bearings of series 223A

Where bore diameters of 160 mm and more are required (bore reference number  $\geq 32$ ), FAG recommends to use its field-proven special spherical roller bearings of design 223A.MA.T41A, fig. 2.

The bearings have a fixed centre lip on the inner ring and two lateral retaining lips. The two-piece machined brass cage (suffix MA) is of the outer ring riding type.

## 2: Design 223A.MA.T41A of the special spherical roller bearings for vibrating machines (bore reference number $\geq 32$ )

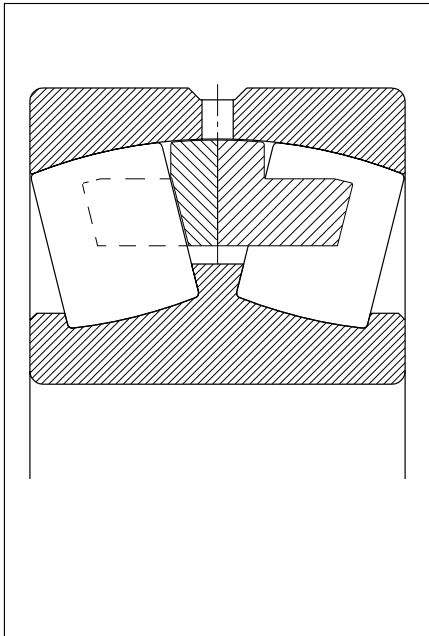

## 1.2.3 Spherical roller bearings of series 233A

For applications where the highest possible load carrying capacity is required in vibrating machines, special spherical roller bearings of series 233A(S).MA.T41A with bearing bores ranging from 100 to 200 mm (bore reference numbers 20 to 40) are available.

These bearings have three fixed lips on the inner ring. The split machined brass cage (suffix MA) is guided in the outer ring.

## 1.3 Bearings with a tapered bore

Special spherical roller bearings for vibrating machines usually have a cylindrical bore. For special applications, e.g. saw frames, bearings with a tapered bore (taper 1:12) are also available. These designs are suffixed EK.T41A or AK.MA.T41A.

## 1.4 Bearings with a chromium-plated bore

In order to reduce or prevent fretting corrosion between the bearing bore and the shaft, FAG supplies spherical roller bearings with a thin-layer chromium-plated bore to order. They ensure that the displaceability (floating bearing function) between bearing bore and shaft, which is necessary due to thermal influences, will be maintained for a long period of operation.

The bearings with a chromium-plated bore have the same dimensions and tolerances as the FAG standard bearings for

vibrating machines and are interchangeable with them.

The thin-layer chromium plating can be ordered indicating the suffix J24BA.

Order designation (example):  
22324E.J24BA.T41A

## 1.5 Specification T41A

The FAG spherical roller bearings for vibrating machines are produced in accordance with specification T41A. It takes into account the specific requirements of this application. In this specification the tolerances and the radial clearance of the special spherical roller bearings are defined.

### 1.5.1 Tolerances of bearing bore and outside diameter

The specification T41A prescribes a restriction of the bore tolerance to the upper half of the normal tolerance field. The outside diameter must be in the centre half of the normal tolerance field. In bearings with a tapered bore, only the outside diameter tolerances are in the reduced tolerance range. For the tolerance values, see table, fig. 3.

In this way, with the shaft tolerances g6 or f6, the sliding fit required for the inner ring, and with the housing tolerance P6 the interference fit required for the outer ring are safely achieved. The inner ring is not subjected to a pure point load, and the outer ring is subjected to circumferential loads.

The other tolerances correspond to the tolerance class PN according to DIN 620.

# FAG Spherical Roller Bearings for Vibratory Stressing

## Specification T41A

### 3: Reduced tolerance according to FAG specification T41A

#### Inner ring

|                                 |         | Dimensions in mm            |          |           |            |            |            |
|---------------------------------|---------|-----------------------------|----------|-----------|------------|------------|------------|
| Nominal bearing bore            | over to | 30<br>50                    | 50<br>80 | 80<br>120 | 120<br>180 | 180<br>250 | 250<br>315 |
|                                 |         | Tolerances in $\mu\text{m}$ |          |           |            |            |            |
| Deviation $\Delta_{\text{Dmp}}$ |         | 0<br>-7                     | 0<br>-9  | 0<br>-12  | 0<br>-15   | 0<br>-18   | 0<br>-21   |

#### Outer ring

|                                 |         | Dimensions in mm            |            |            |            |            |            |
|---------------------------------|---------|-----------------------------|------------|------------|------------|------------|------------|
| Nominal O.D.                    | over to | 80<br>150                   | 150<br>180 | 180<br>315 | 315<br>400 | 400<br>500 | 500<br>630 |
|                                 |         | Tolerances in $\mu\text{m}$ |            |            |            |            |            |
| Deviation $\Delta_{\text{Dmp}}$ |         | -5<br>-13                   | -5<br>-18  | -10<br>-23 | -13<br>-28 | -13<br>-30 | -15<br>-35 |

### 4: Radial clearance of the FAG spherical roller bearings

|                      |         | Dimensions in mm |          |          |          |           |            |            |            |            |            |            |            |            |            |
|----------------------|---------|------------------|----------|----------|----------|-----------|------------|------------|------------|------------|------------|------------|------------|------------|------------|
| Nominal bearing bore | over to | 30<br>40         | 40<br>50 | 50<br>65 | 65<br>80 | 80<br>100 | 100<br>120 | 120<br>140 | 140<br>160 | 160<br>180 | 180<br>200 | 200<br>225 | 225<br>250 | 250<br>280 | 280<br>315 |

#### with cylindrical bore

|                 |            | Bearing clearance in $\mu\text{m}$ |           |           |            |            |            |            |            |            |            |            |            |            |            |
|-----------------|------------|------------------------------------|-----------|-----------|------------|------------|------------|------------|------------|------------|------------|------------|------------|------------|------------|
| Clearance group | min<br>max |                                    |           |           |            |            |            |            |            |            |            |            |            |            |            |
|                 |            | C3                                 | 45<br>60  | 55<br>75  | 65<br>90   | 80<br>110  | 100<br>135 | 120<br>160 | 145<br>190 | 170<br>220 | 180<br>240 | 200<br>260 | 220<br>290 | 240<br>320 | 260<br>350 |
| C4              | min<br>max | 60<br>80                           | 75<br>100 | 90<br>120 | 110<br>145 | 135<br>180 | 160<br>210 | 190<br>240 | 220<br>280 | 240<br>310 | 260<br>340 | 290<br>380 | 320<br>420 | 350<br>460 | 370<br>500 |

#### with tapered bore

|                 |            | Bearing clearance in $\mu\text{m}$ |           |           |            |            |            |            |            |            |            |            |            |            |            |
|-----------------|------------|------------------------------------|-----------|-----------|------------|------------|------------|------------|------------|------------|------------|------------|------------|------------|------------|
| Clearance group | min<br>max |                                    |           |           |            |            |            |            |            |            |            |            |            |            |            |
|                 |            | C3                                 | 50<br>65  | 60<br>80  | 75<br>95   | 95<br>120  | 110<br>140 | 135<br>170 | 160<br>200 | 180<br>230 | 200<br>260 | 220<br>290 | 250<br>320 | 270<br>350 | 300<br>390 |
| C4              | min<br>max | 65<br>85                           | 80<br>100 | 95<br>120 | 120<br>150 | 140<br>180 | 170<br>220 | 200<br>260 | 230<br>300 | 260<br>340 | 290<br>370 | 320<br>410 | 350<br>450 | 390<br>490 | 430<br>540 |

### 5: Radial clearance reduction in spherical roller bearings with a tapered bore (solid shaft)

| Nominal bearing bore |     | Reduction of the bearing clearance |       | Axial displacement on taper 1:12 |      |               |      | Check values for the smallest radial clearance after mounting |        |        |
|----------------------|-----|------------------------------------|-------|----------------------------------|------|---------------|------|---|--------|--------|
| d over mm            | to  | min mm                             | max   | Shaft min mm                     | max  | Sleeve min mm | max  | CN min mm   | C3 min | C4 min |
| 30                   | 40  | 0.02                               | 0.025 | 0.35                             | 0.4  | 0.35          | 0.45 | 0.015   | 0.025  | 0.04   |
| 40                   | 50  | 0.025                              | 0.03  | 0.4                              | 0.45 | 0.45          | 0.5  | 0.02  | 0.03   | 0.05   |
| 50                   | 65  | 0.03                               | 0.04  | 0.45                             | 0.6  | 0.5           | 0.7  | 0.025   | 0.035  | 0.055  |
| 65                   | 80  | 0.04                               | 0.05  | 0.6                              | 0.75 | 0.7           | 0.85 | 0.025   | 0.04   | 0.07   |
| 80                   | 100 | 0.045                              | 0.06  | 0.7                              | 0.9  | 0.75          | 1    | 0.035   | 0.05   | 0.08   |
| 100                  | 120 | 0.05                               | 0.07  | 0.7                              | 1.1  | 0.8           | 1.2  | 0.05  | 0.065  | 0.1    |
| 120                  | 140 | 0.065                              | 0.09  | 1.1                              | 1.4  | 1.2           | 1.5  | 0.055   | 0.08   | 0.11   |
| 140                  | 160 | 0.075                              | 0.1   | 1.2                              | 1.6  | 1.3           | 1.7  | 0.055   | 0.09   | 0.13   |
| 160                  | 180 | 0.08                               | 0.11  | 1.3                              | 1.7  | 1.4           | 1.9  | 0.06  | 0.1    | 0.15   |
| 180                  | 200 | 0.09                               | 0.13  | 1.4                              | 2    | 1.5           | 2.2  | 0.07  | 0.1    | 0.16   |
| 200                  | 225 | 0.1                                | 0.14  | 1.6                              | 2.2  | 1.7           | 2.4  | 0.08  | 0.12   | 0.18   |
| 225                  | 250 | 0.11                               | 0.15  | 1.7                              | 2.4  | 1.8           | 2.6  | 0.09  | 0.13   | 0.2    |
| 250                  | 280 | 0.12                               | 0.17  | 1.9                              | 2.6  | 2             | 2.9  | 0.1   | 0.14   | 0.22   |
| 280                  | 315 | 0.13                               | 0.19  | 2                                | 3    | 2.2           | 3.2  | 0.11  | 0.15   | 0.24   |

### 1.5.2 Radial clearance groups, radial clearance reduction in bearings with a tapered bore

The specification T41A defines C4 as the standard clearance group for all spherical roller bearings in vibrating screen design, so that it must not be indicated specifically any longer. In this way a detrimental radial preloading of the bearings in the event of unfavourable combinations of various influences such as fits, deformations etc. is safely prevented. This applies especially to the startup and run-in periods when the temperature gradient between inner ring and outer ring is particularly high.

Only in rare cases, e.g. if the screened material is hot, or if the bearing location is exposed to extremely high external heating, a different radial clearance must be considered for the spherical roller bearings in vibrating machines.

For special applications, e.g. saw frames, bearings with a bearing clearance other than C4 may be required. In such cases, the suffix for the clearance, e.g. C3, has to be indicated uncoded. FAG bearings of this design are available on request. Radial clearance values for the special spherical roller bearings are indicated in the table, fig. 4.

Bearings with a tapered bore are usually mounted onto a tapered shaft seat. The radial clearance reduction during mounting (see table, fig. 5) can serve as a yardstick for the fit between inner ring and shaft.

# FAG Spherical Roller Bearings for Vibratory Stressing

## Dimensioning of the Bearings

### 1.6 Attainable radial acceleration

As the centrifugal forces toward the outer ring are radially supported the special spherical roller bearings in vibrating machines can accommodate high accelerations, see diagram below.

#### Attainable radial acceleration values for the special spherical roller bearings for vibrating machines

- a)  $n \cdot d_m = 350\,000 \text{ min}^{-1} \cdot \text{mm}$   
maximum attainable values under optimum mounting conditions and oil lubrication, e.g. planetary gears
- b)  $n \cdot d_m = 140\,000 \text{ min}^{-1} \cdot \text{mm}$   
usual operating conditions for saw frames with grease lubrication
- c)  $n \cdot d_m = 230\,000$  up to  $300\,000 \text{ min}^{-1} \cdot \text{mm}$   
usual application for vibrating screens with grease or oil lubrication

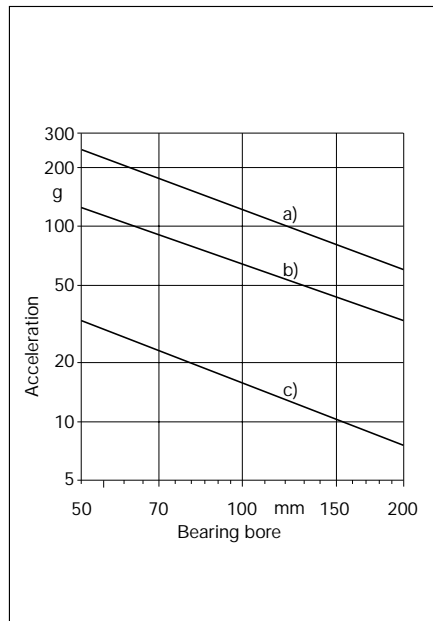

### 1.7 Heat treatment

All FAG spherical roller bearings of series 223 and 233 for vibratory stressing can be used at operating temperatures of up to 200 °C. This temperature limit also applies to the metal cages in the bearings.

## 2 Dimensioning of the bearings

Bearing arrangements which are comparable with field-proven arrangements can be dimensioned on the basis of the index of dynamic stressing  $f_L$ , provided that the boundary conditions are comparable as well. Usually, vibrating screen bearings are designed for  $f_L$  values between 2.5 and 3.

$$f_L = (C/P) \cdot f_n$$

C dynamic load rating [kN], see bearing tables, section 5

P equivalent dynamic load [kN], see sections 2.1 to 2.3

$f_n$  speed factor, see catalogue WL 41 520

When determining the equivalent dynamic load P of the spherical roller bearings for applications involving vibratory stressing those influences which cannot be defined precisely are taken into account by a safety factor of  $f_z = 1.2$  with which the radial bearing load  $F_r$  is multiplied. Experience shows that sufficiently long operating periods are thus achieved.

### 2.1 Two bearing screen with circle throw

Fig. 6 shows the principle of an imbalance-type two bearing screen.

The bearing load imposed by the centrifugal force of the screen box constituted by the screen box weight, the vibration radius and the speed is obtained using the following equation:

$$F_r = \frac{1}{z} \cdot \frac{m}{10^3} \cdot r \cdot \omega^2 = \frac{1}{z} \cdot \frac{G}{g} \cdot r \left( \frac{\pi \cdot n}{30} \right)^2 \quad [\text{kN}] \quad (1)$$

$F_r$  radial bearing load [kN]

m screen box mass [kg]

r vibration radius [m]

$\omega$  angular velocity [1/s]

G screen box weight [kN]

g acceleration due to gravity [m/s<sup>2</sup>]

n speed [min<sup>-1</sup>]

z number of bearings

The vibration radius r of two bearing screens can be calculated from the ratio of the screen box weight to the imbalance weight. Since two bearing screens generally work far beyond the critical range approaching the operational amplitude the common centroidal axis of the two masses (screen box and imbalance mass) can be assumed to persevere during rotation, fig. 7.

Hence

$$G \cdot r = G_1 (R - r)$$

and the vibration radius

$$r = \frac{G_1 \cdot R}{G + G_1} \quad [\text{m}] \quad (2)$$

where

G weight of screen box [kN]

$G_1$  imbalance weight [kN]

R distance between the centre of gravity of imbalance and the bearing axis [m]

r vibration radius of the screen box [m]

$G_1 \cdot R$  imbalance moment of the exciter unit [kN m]

$G + G_1$  total weight supported by springs [kN]

Introducing equation (2) into equation (1) and transforming the expression, the radial bearing load

$$F_r = \frac{1}{z} \cdot \frac{G_1}{g} \cdot \frac{R}{1 + \frac{G_1}{G}} \cdot \left( \frac{\pi \cdot n}{30} \right)^2 \quad [\text{kN}] \quad (3)$$

# Dimensioning of the Bearings

## Two bearing screen with circle throw

### 6: Principle of a two bearing screen with circle throw

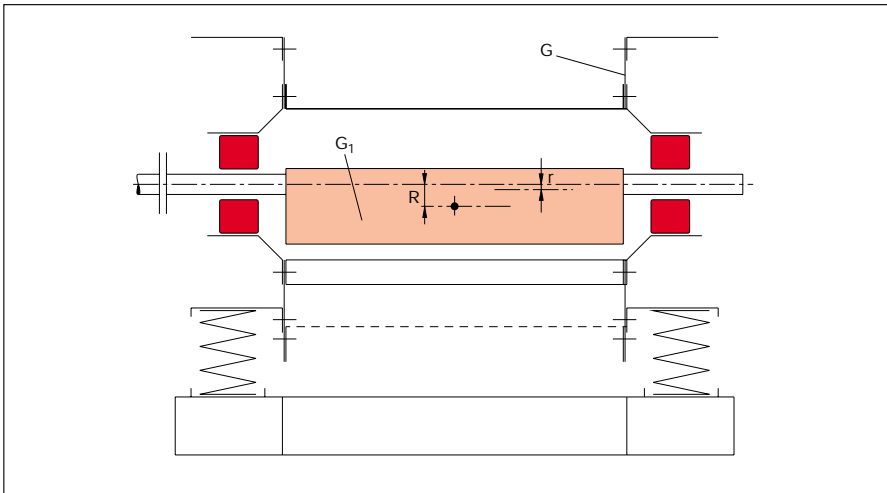

### Example

Screen box weight  $G = 35 \text{ kN}$   
 Vibration radius  $r = 0.003 \text{ m}$   
 Speed  $n = 1200 \text{ min}^{-1}$   
 Number of bearings  $z = 2$

Bearing load according to equation (1)

$$F_r = \frac{1}{2} \cdot \frac{35}{9.81} \cdot 0.003 \left( \frac{\pi \cdot 1200}{30} \right)^2 = 84.5 \text{ [kN]}$$

The equivalent dynamic bearing load needed to determine the required dynamic load rating of the bearing

$$P = 1.2 \cdot F_r = 1.2 \cdot 84.5 = 101 \text{ [kN]}$$

### 7: The vibration radius is a function of the screen box weight and the imbalance weight

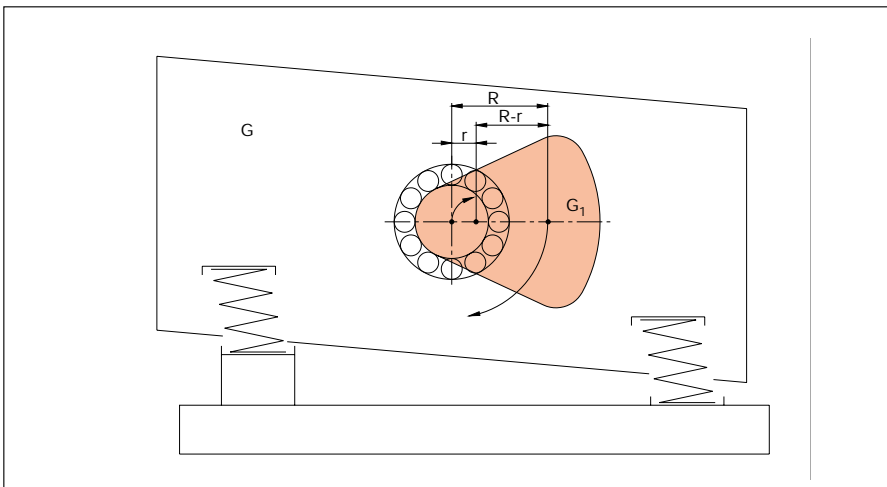

# Dimensioning of the Bearings

## Two bearing screen with straight-line motion

### 2.2 Two bearing screen with straight-line motion

Basically, the exciter unit of a two bearing screen with straight-line motion consists of two contra-rotating synchronous circular throw systems, fig. 8.

The forces involved are determined by resolving the rotating centrifugal force vectors of the imbalance shafts into two components: one in the direction of the line connecting the two shafts and the other perpendicular to this line. It can be readily seen that the components lying in the direction of the shaft connecting line in overall effect cancel each other out, whereas the perpendicular components add up, generating a harmonic pulsating inertia force. This force is responsible for the straight line motions of the screen box.

Since, in the direction of vibration, the overcritical operation enables the so-called static amplitude to be reached and the common centroidal axis of the screen box and the imbalance masses does not vary during vibration the bearing loads are as follows:

In the direction of vibration

$$F_{r \min} = \frac{1}{z} \cdot \frac{m}{10^3} \cdot r \cdot \omega^2 =$$

$$= \frac{1}{z} \cdot \frac{G}{g} \cdot r \cdot \left( \frac{\pi \cdot n}{30} \right)^2 =$$

$$= \frac{1}{z} \cdot \frac{G_1}{g} \cdot (R - r) \cdot \left( \frac{\pi \cdot n}{30} \right)^2 \text{ [kN]} \quad (4)$$

where

$r$  [m] amplitude of the linear vibration

$R$  [m] distance between the centres of gravity of imbalance and the pertinent bearing axes

Perpendicular to the direction of vibration

$$F_{r \max} = \frac{1}{z} \cdot \frac{G_1}{g} \cdot R \cdot \left( \frac{\pi \cdot n}{30} \right)^2 \text{ [kN]} \quad (5)$$

meaning that the bearing load is slightly higher.

Contrary to a circle throw screen with a constant bearing load, the bearing loads on a straight-line motion screen vary twice between  $F_{r \max}$  and  $F_{r \min}$  during one revolution of the eccentric drive shafts

Comparing equation (4) with equation (1) shows that the minimum bearing load accommodated by a straight-line motion screen is exactly the same as that of a circle throw screen.

For a straight-line screen whose loading varies according to a sinusoidal pattern the bearing load can be calculated using the formula

$$F_r = 0.68 \cdot F_{r \max} + 0.32 \cdot F_{r \min} \text{ [kN]}$$

With a circle throw screen, the bearing load can be determined from the screen box weight  $G$ , the vibration radius  $r$  and the speed  $n$ . With a straight-line screen, these data merely allow the minimum load to be determined. An accurate calculation is only possible if either the imbalance weight  $G_1$  or the distance  $R$  between the centres of gravity of imbalance and their pertinent bearing axes are known as well. The unknown quantity can then be determined from

$$G \cdot r = G_1 (R - r) \text{ [kN m]}$$

### Example

Screen box weight  $G = 33$  kN

Imbalance weight  $G_1 = 7.5$  kN

Amplitude  $r = 0.008$  m

Speed  $n = 900$  min<sup>-1</sup>

Number of bearings  $z = 4$

$$\text{With } R = \frac{r(G + G_1)}{G_1} =$$

$$= \frac{0.008(33 + 7.5)}{7.5} = 0.0432 \text{ [m]}$$

then, according to (4) and (5)

$$F_{r \min} = \frac{1}{4} \cdot \frac{33}{9.81} \cdot 0.008 \cdot \left( \frac{\pi \cdot 900}{30} \right)^2$$

$$= 59.8 \text{ [kN]}$$

$$F_{r \max} = \frac{1}{4} \cdot \frac{7.5}{9.81} \cdot 0.0432 \cdot \left( \frac{\pi \cdot 900}{30} \right)^2$$

$$= 73.3 \text{ [kN]}$$

The bearing load

$$F_r = 0.68 \cdot 73.3 + 0.32 \cdot 59.8 =$$

$$= 69 \text{ [kN]}$$

Then, the equivalent dynamic bearing load required for determining the dynamic load rating

$$P = 1.2 \cdot 69 = 83 \text{ [kN]}$$

## 8: Principle of a two bearing screen with straight-line motion

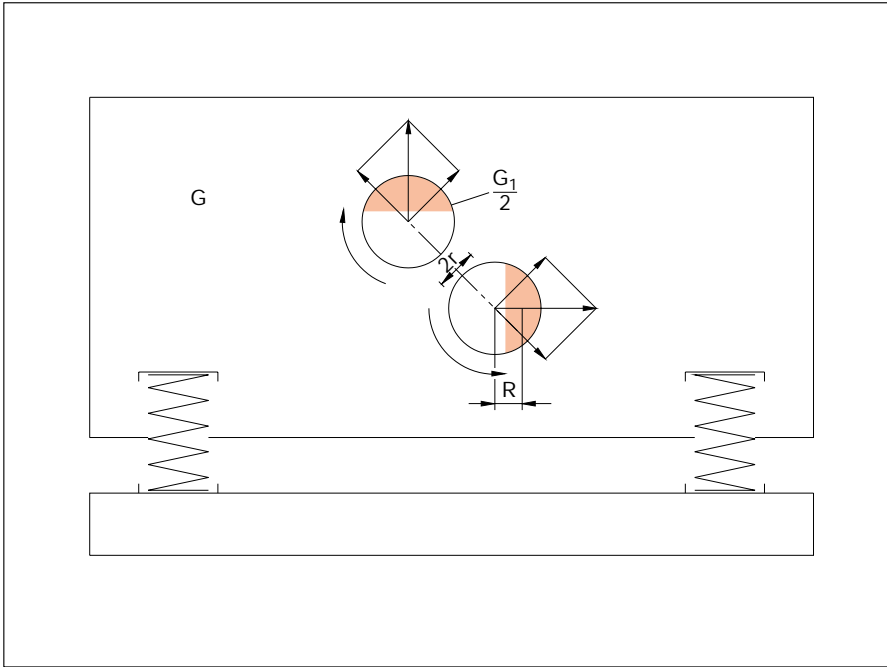

# Dimensioning of the Bearings

## Four bearing screen

### 2.3 Four bearing or eccentric screen

In contrast to a two bearing screen, the vibration radius of a four bearing screen is a function of the shaft eccentricity. The bearing load accommodated by the two inner bearings is determined using the same equation as for the circle throw screen:

$$F_r = \frac{1}{z} \cdot \frac{G}{g} \cdot r \left( \frac{\pi \cdot n}{30} \right)^2 \quad [\text{kN}] \quad (1)$$

where  $r$  is the eccentric radius of the crankshaft and  $z$  is the number of inner bearings, fig. 9.

The effect of the support springs on the loading of the inner bearings is negligible.

The outer bearings of the four bearing screen are only lightly loaded since during idling of the screen the centrifugal forces of the screen box are compensated by counterweights ( $G_2$ ). The load on these bearings is not constant and follows, because of the action of the support springs, a sinusoidal pattern. In operation the material in the box interferes with the balanced condition of the machine. This means some extra load on the outer bearings. However, the effect of this additional loading is also small.

The selection of the bearings depends on the shaft diameter. This results in bearings whose load carrying capacity is so high that a fatigue life analysis is unnecessary. Since these bearings do not perform vibrating motions the standard spherical roller bearing design suffices.

### 9: Principle of a four bearing screen

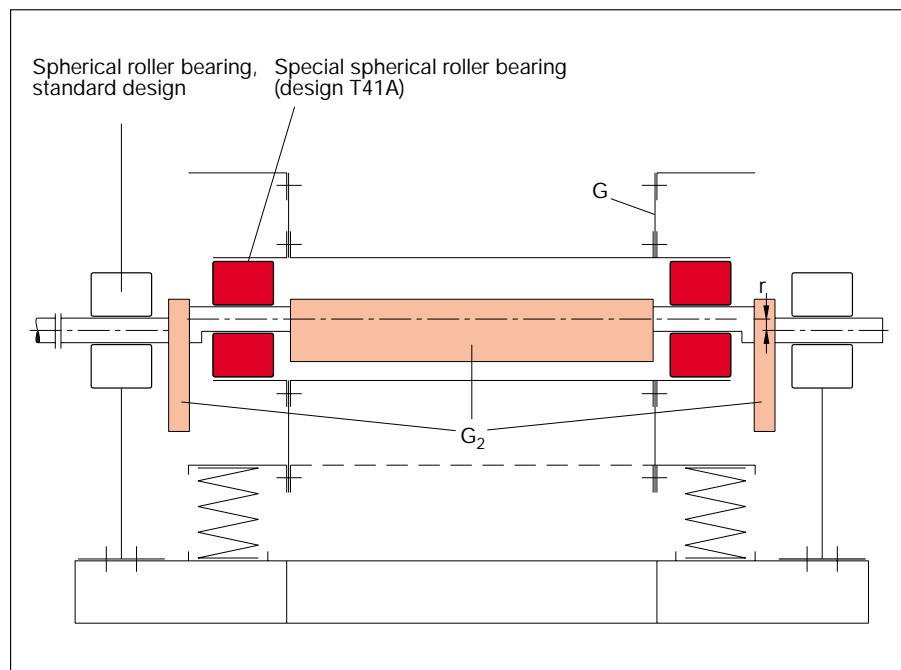

#### Example

Screen box weight  $G = 60 \text{ kN}$

Eccentric radius  $r = 0.005 \text{ m}$

Speed  $n = 850 \text{ min}^{-1}$

Number of bearings  $z = 2$

Inner bearings:

Bearing load according to equation (1)

$$F_r = \frac{1}{2} \cdot \frac{60}{9.81} \cdot 0.005 \left( \frac{\pi \cdot 850}{30} \right)^2 = 121 \text{ kN}$$

Then, the equivalent dynamic bearing load required to determine the dynamic load rating of the bearing

$$P = 1.2 \cdot 121 = 145 \text{ [kN]}$$

# Dimensioning of the Bearings

## Centrifugal force nomogram

### 2.4 Centrifugal force nomogram for calculating the centrifugal forces of the imbalance masses and the screen box masses

$F_{max}$ ,  $F_{min}$  and  $F$  are the centrifugal forces  
 $n$  is the speed [ $min^{-1}$ ]  
 $r$  is the vibration radius [m]  
 $R$  is the distance between the centre of gravity of imbalance and shaft axis [m]

$b$  is the acceleration [ $m/s^2$ ]  
 $G$  is the weight of the screen box [kN]  
 $G_1$  is the weight of imbalance [kN]  
 $g = 9.81$  is the gravitational acceleration [ $m/s^2$ ]

$$F_{max} = \frac{G_1}{g} \cdot R \cdot \left(\frac{\pi \cdot n}{30}\right)^2 \text{ [kN]}$$

$$F_{min} = \frac{G_1}{g} \cdot (R - r) \cdot \left(\frac{\pi \cdot n}{30}\right)^2 \text{ [kN]}$$

$$F = \frac{G}{g} \cdot r \cdot \left(\frac{\pi \cdot n}{30}\right)^2 \text{ [kN]}$$

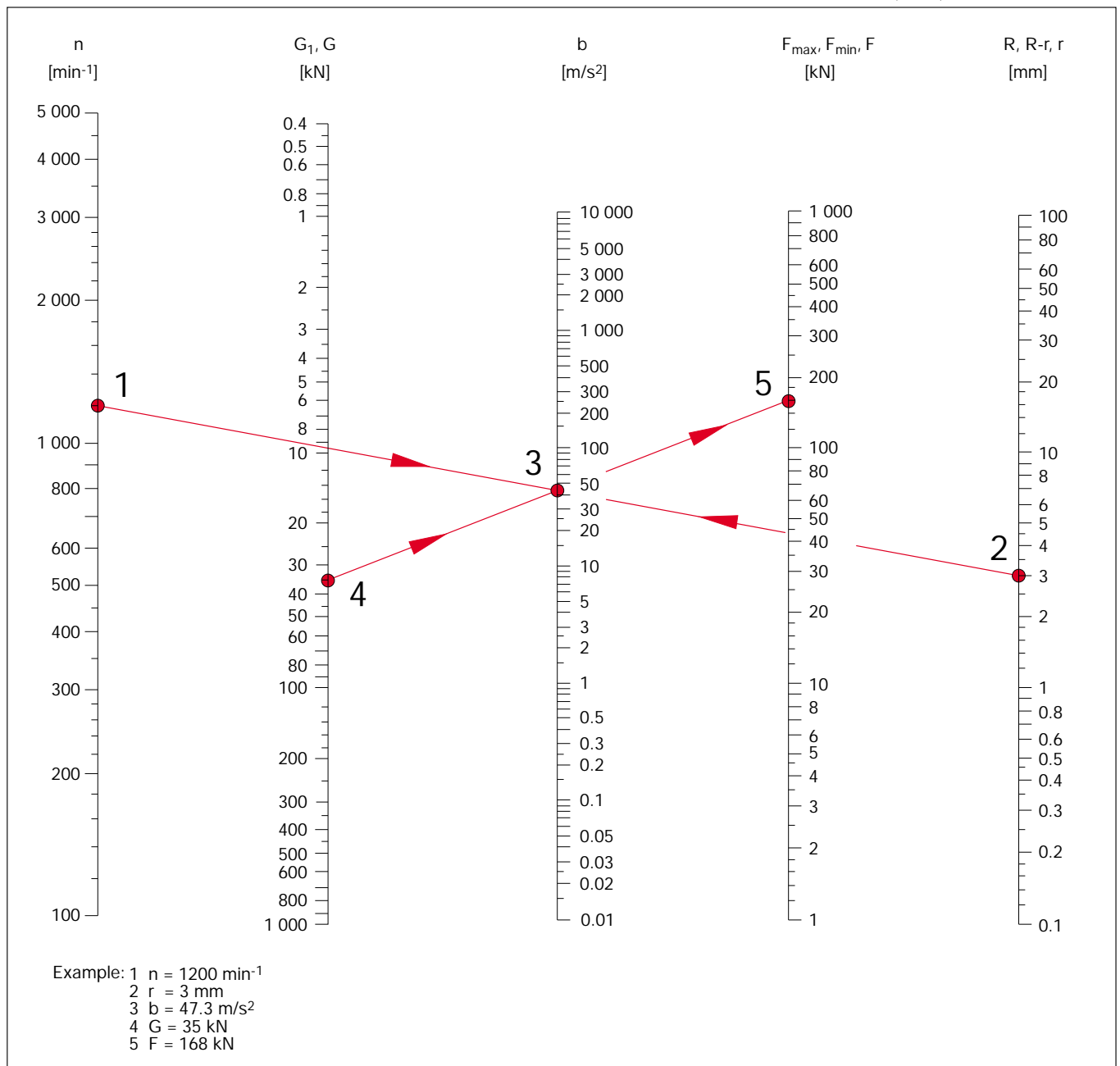

# Dimensioning of the Bearings

## Load rating nomogram

### 2.5 Load rating nomogram for determining the required dynamic load rating and the theoretical fatigue life

$$C = P \cdot \frac{f_L}{f_n} \quad [\text{kN}]$$

C dynamic load rating  
 P equivalent dynamic load  
 $f_L$  index of dynamic stressing  
 $f_n$  speed factor

[kN]  
 [kN]

Two bearing screens with circle throw  
 and inner bearings of four bearing screens

$$P = 1.2 \cdot \frac{F}{z} \quad [\text{kN}]$$

Two bearing screens with straight-line  
 motion

$$P = 1.2 \cdot \left( \frac{0.68 \cdot F_{\max} + 0.32 \cdot F_{\min}}{z} \right)$$

1.2 is the supplementary factor  
 $z$  is the number of bearings  
 $F$  is the centrifugal force from  
 nomogram 1 (section 2.4)

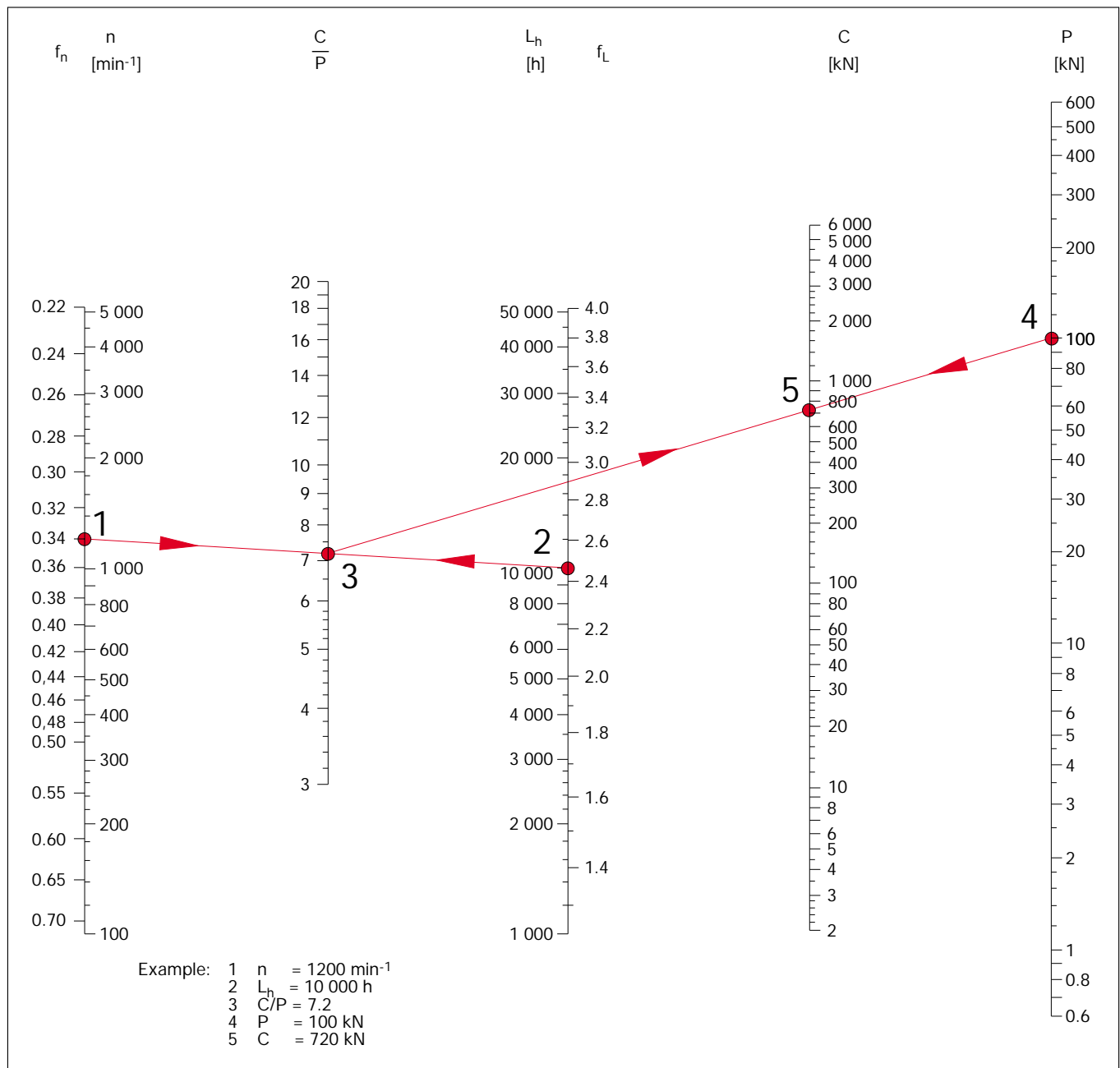

### 3 Design characteristics

#### 3.1 Two bearing screen with circle throw (grease lubrication)

Fig. 10 shows the basic layout of the bearing mounting in a two bearing screen with circle throw and grease lubrication. The imbalance shaft is supported in two special spherical roller bearings FAG 223..E.T41A or FAG 233..AS.MA.T41A. The drive end bearing acts as the locating bearing, and the opposite bearing as the floating bearing.

#### Mounting and dismounting of the bearings

The mating parts are inspected and the bearing mounted into the housing bore. Smaller bearings can be mounted cold whereas with larger ones the housing should be heated uniformly until the interference between bearing O.D. and housing bore is eliminated. As the housing cools down, an interference fit results. Then bearing and housing are mounted on the shaft.

Removal of the bearing from the housing is facilitated by replacing the guard tube flange (part A in fig. 10) with a ring circumferentially fitted with several removal screws.

#### Lubrication and sealing

The grease supply system shown in fig. 10 is quite convenient due to the circumferential groove and the lubricating holes in the outer ring of the bearing. Thus the fresh grease makes its way directly to the rolling and sliding surfaces of the rolling bearing and ensures a uniform lubrication of the two rows of rollers.

The fresh grease displaces the spent and – possibly – contaminated grease from the bearing cavities. At the inboard end of the bearing mounting the spent

grease escapes through the gap in the grease baffle and is deposited within the guard tube. At the outboard end the spent grease gathers in the grease collecting pocket from where it is periodically removed.

A relubricatable labyrinth seals the bearing arrangement against the ingress of contaminants. A V ring can be inserted in the inward passage of the labyrinth ring to further increase the sealing efficiency.

10: Two bearing screen with circle throw (grease lubrication)

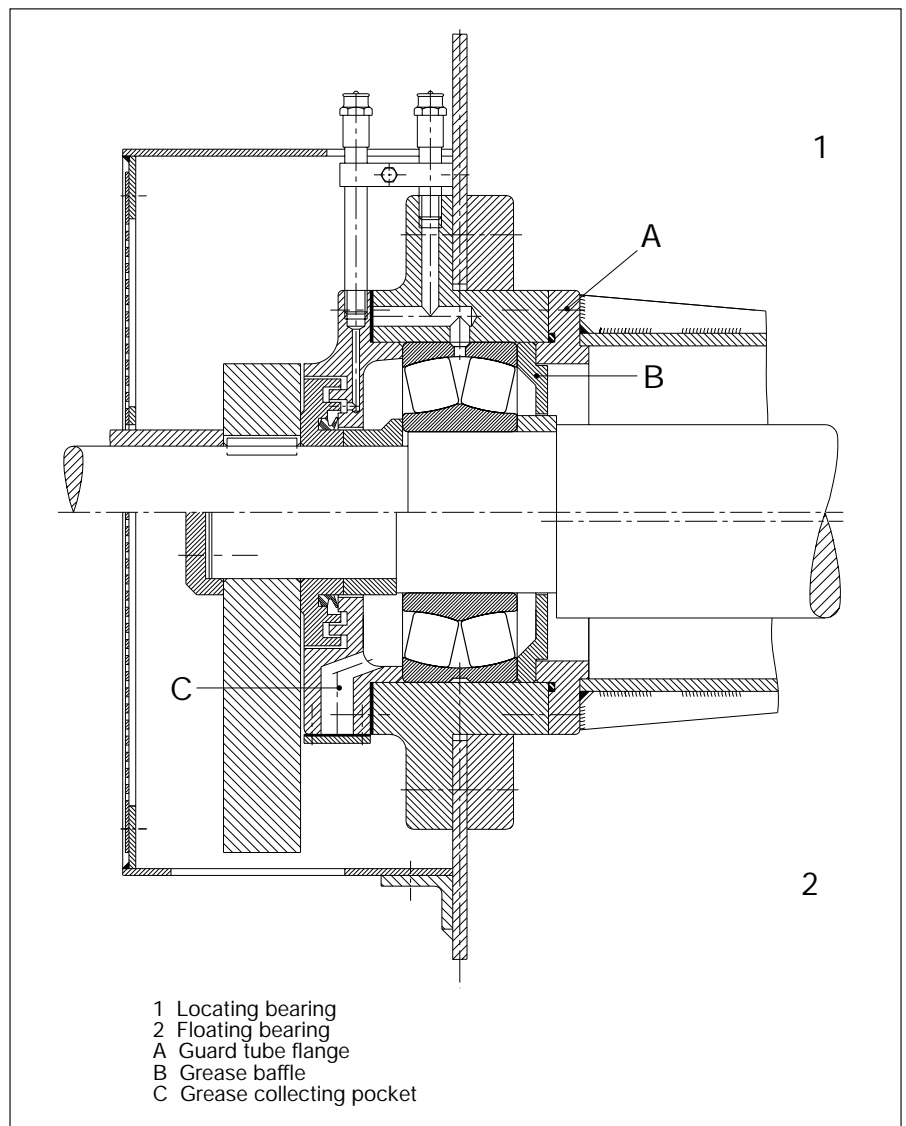

# Design Characteristics

## Two bearing screen with circle throw (oil sump lubrication)

### 3.2 Two bearing screen with circle throw (oil sump lubrication)

Fig. 11 shows the basic layout of the bearing mounting in a two bearing screen with circle throw and oils sump lubrication.

A grease-filled labyrinth which can be relubricated prevents dirt from penetrating into the bearing from outside. A flinger ring with an oil collecting groove is used to prevent oil from escaping. On the bearing side the sealing area is shielded by a flinger ring.

To prevent the labyrinth grease from penetrating into the oil cavities, a V ring is fitted between labyrinth and flinger ring. The oil level on both sides of the bearing is equalized by means of the connecting bore provided in the bottom of the housing. The oil level should be so high that the bottommost roller of the bearing is about half immersed in the oil with the bearing at rest. This is achieved by the provision of an overflow hole at this level which is plugged up after filling the housing with the required amount of oil. The oil outlet screw contains a small permanent magnet which collects wear particles from the oil. The oil sump should contain the largest possible amount of oil to achieve the longest possible replenishment intervals. Generally, the guard tube around the shaft serves as an additional oil reservoir.

11: Two bearing screen with circle throw (oil sump lubrication)

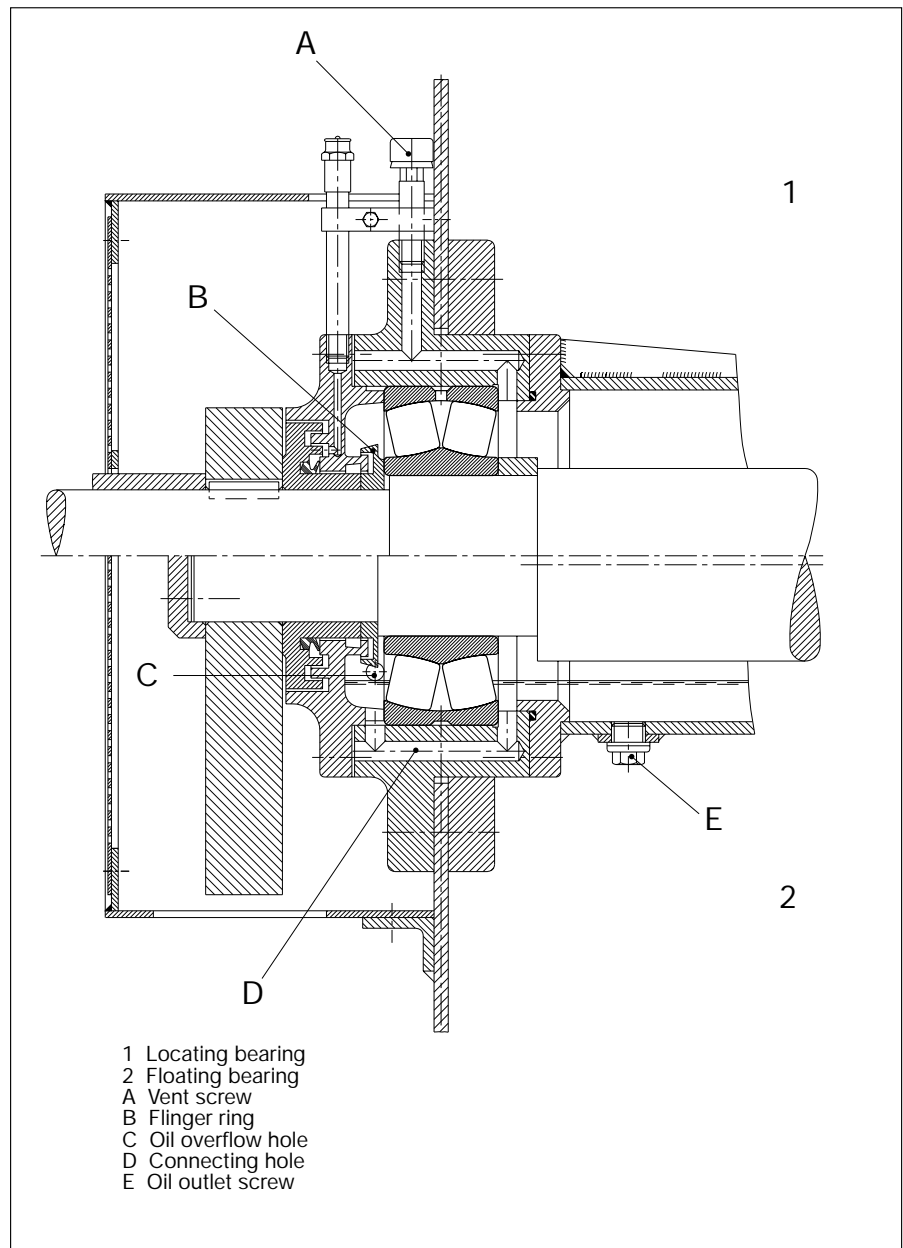

### 3.3 Two bearing screen with circle throw (oil circulation lubrication)

The design of the bearing arrangement with oil circulation lubrication shown in fig. 12 is similar to that of bearing arrangements with oil sump lubrication (see 3.2). The oil level on both sides of the bearing is equalized by the connecting bore in the bottom of the housing.

The sealing was adopted from the system using oil sump lubrication. The level of the oil drain bore is such as to ensure the constant availability of an emergency amount of oil in case the oil supply is interrupted. The oil is supplied through the lubricating groove and lubricating holes in the bearing outer ring. The oil requires constant filtering (cp. section 4.2.2).

12: Two bearing screen with circle throw (oil circulation lubrication)

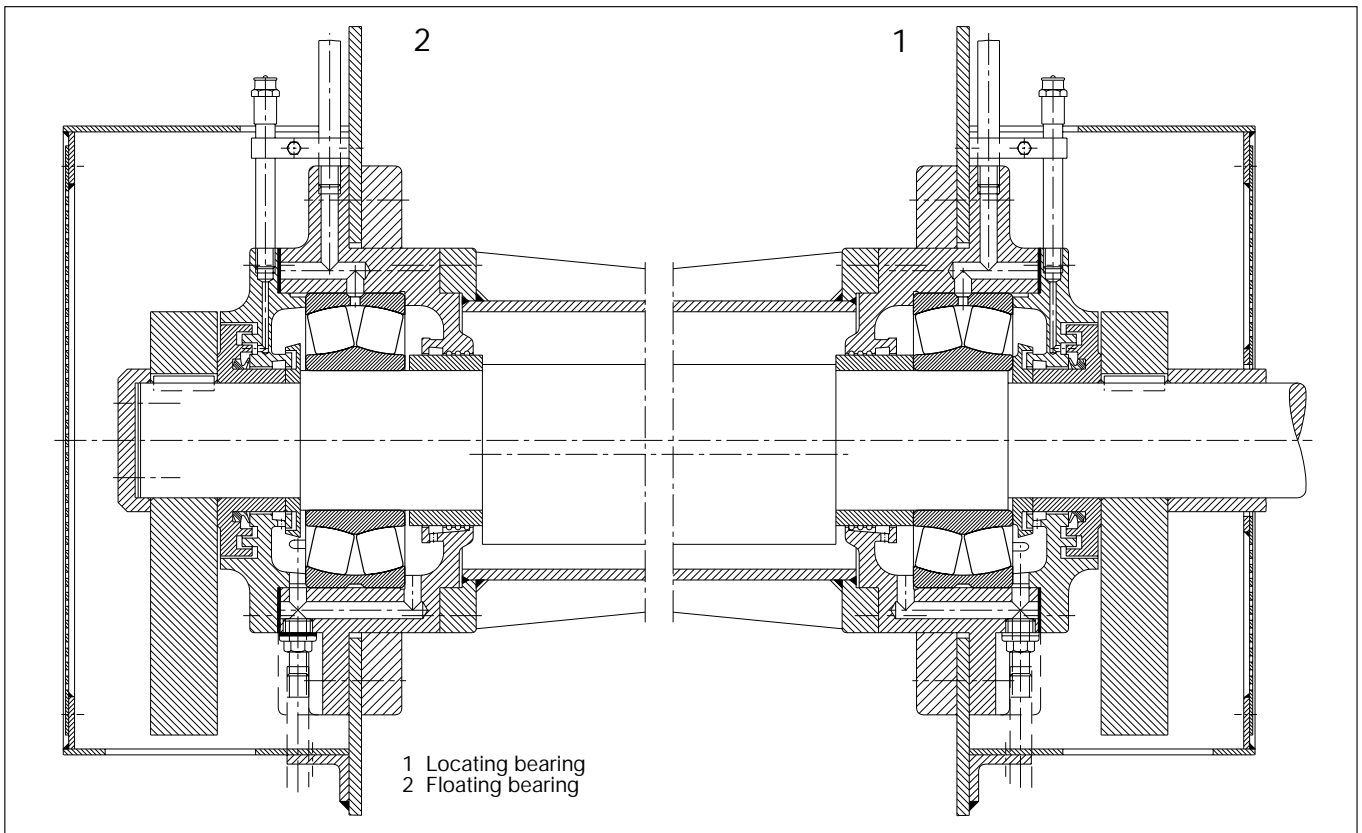

# Design Characteristics

## Two bearing screen with straight-line motion (oil splash lubrication)

### 3.4 Two bearing screen with straight-line motion (oil splash lubrication)

Fig. 13 shows the bearing mounting of an exciter unit for a two bearing screen with straight-line motion. The two contra-rotating, synchronously geared imbalance shafts are mounted on FAG special spherical roller bearings 223..E.T41A. The gear end bearings function as locating

bearings so that the cycling conditions for the gearwheels are not impaired in the event of length variations (temperature differences).

Bearing lubrication is effected by the oil thrown off by the gearwheels and by a flinger ring. Baffle plates provided at the bottom halves of the housing faces ensure an oil level reaching about the centre of

the bottommost roller in the bearing. The passage for the drive shaft is fitted with a flinger seal preceded by a labyrinth as an extra protection against the ingress of dirt. In addition, a V ring can be provided between labyrinth and flinger ring. The oil level is just high enough for the bottom gearwheel and the flinger ring to plunge into the oil sump. Lateral oil level indicators allow the oil level to be inspected.

13: Two bearing screen with straight-line motion (oil splash lubrication)

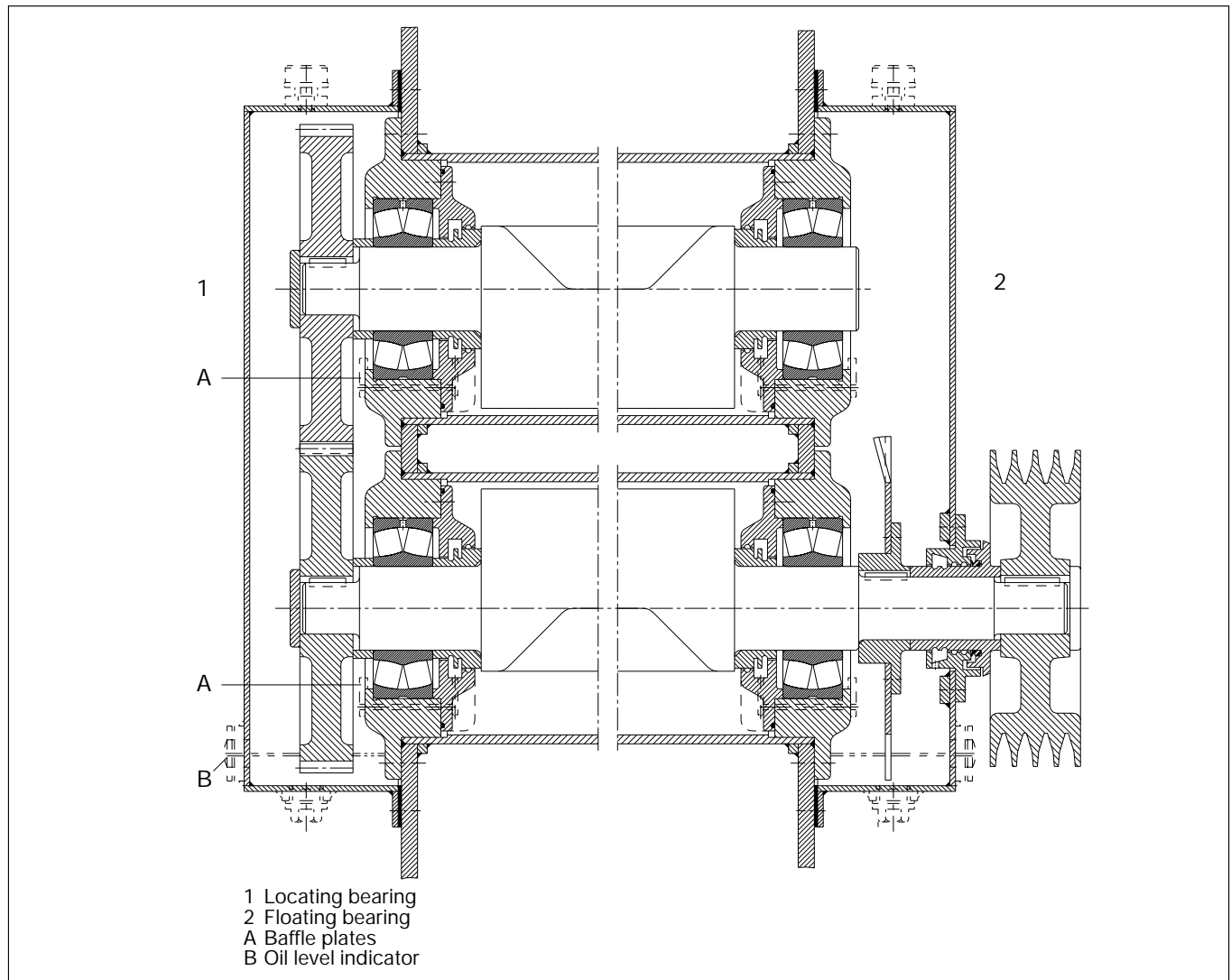

### 3.5 Four bearing screen (grease lubrication)

Fig. 14 shows the eccentric shaft of a four bearing screen. Since the stressing of the inner ring compares with that of the bearings in a two bearing screen the bearings fitted there are FAG special spherical roller bearings of series 223..E or 233..A(S).

Because of the combined action of the revolving centrifugal load from the screen box and the directionally constant spring forces the load acting on the inner ring cannot be called a pure point load; however, the fits are generally the same as those of a two bearing screen. The outer rings are fitted into the housing with P6 and the inner rings are fitted on the shaft with f6 or g6.

One of the two inner bearings functions as the locating bearing and the other one as the floating bearing whose inner ring is displaceable along the shaft. In all other respects the design of the illustrated inner bearing mounting is entirely identical with that of a grease-lubricated two bearing screen.

Conditions are different with the outer bearings. To eliminate, if possible, the transmission of imbalance loads to the foundations and reduce the radial bearing load the imbalance moment of the screen box is counterbalanced in a four bearing screen by means of imbalance weights. When idling the outer bearings are merely stressed from the support springs.

The support springs are preloaded to such an extent that the outer bearings are subjected to a sinusoidally pulsating but directionally constant radial load. The material being screened interferes to some extent with perfect balancing during operation because it causes an unbalanced revolving centrifugal force to be superimposed on the spring forces. Therefore, the load direction can vary within a certain angle. Still, point load is assumed to act on the outer ring in determining the bearing fits.

Loose housing fits must therefore be selected for the outer rings. The inner

rings – as shown in the drawing – are usually mounted onto the shaft with withdrawal sleeves.

The drive end bearing is the locating bearing, whereas the opposite one is the floating bearing; its outer ring is axially displaceable.

The usual, field-proven machining tolerances for the outer bearing seats are:

Shaft: h8/h9  
(withdrawal sleeve mounting)

Housing: H7

The outer bearings which are only lightly loaded and perform no translational movements can be standard spherical roller bearings with a tapered bore and normal clearance.

14: Four bearing screen (grease lubrication)

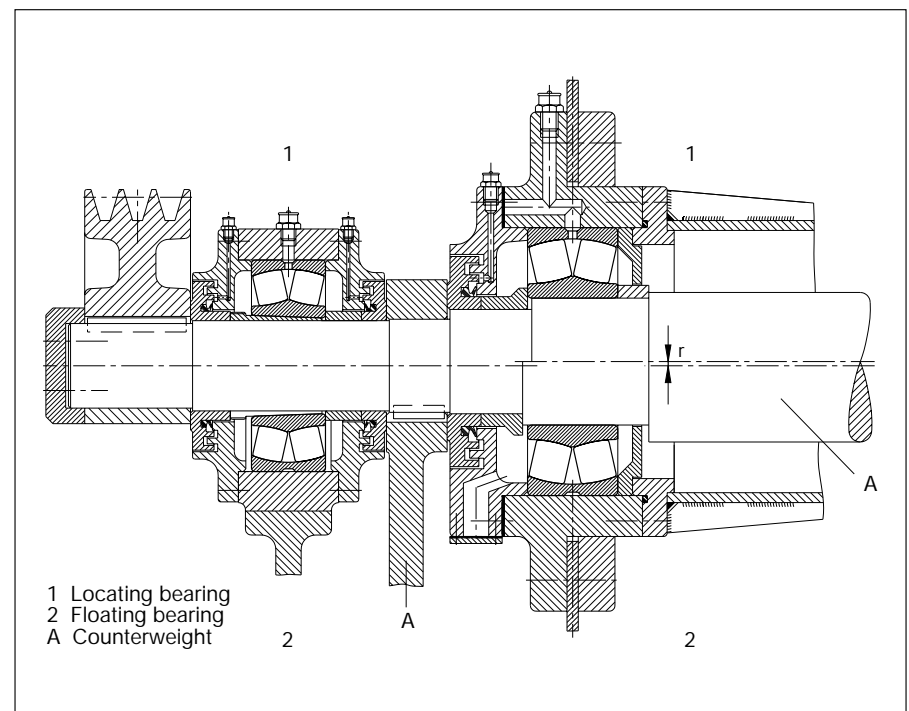

# Lubrication

## Grease lubrication

### 4 Lubrication

Spherical roller bearings in vibrating machines are subjected to very high operating loads and adverse environmental conditions. The lubricant type, lubrication system and lubricant supply have to be selected carefully and adapted to the requirements on the functionality and service life of the vibrating machine bearings.

Depending on the operating conditions, the bearing size and specific requirements of the plant operator, either grease lubrication or oil lubrication can be selected.

#### 4.1 Grease lubrication

In most vibrating machines the special spherical roller bearings are lubricated with grease. Grease lubrication is commonly used up to speed indices of  $n \cdot d_m = 300\,000 \text{ min}^{-1} \cdot \text{mm}$  ( $n$  operating speed,  $d_m$  mean bearing diameter). Only field-proven and tested greases should be used, see section 4.3. If possible, the grease type used should not be changed.

For the usual operating conditions in vibrating machines, we recommend to use lithium soap base greases with EP additives and anti-corrosion additives of penetration class 2. The minimum requirements defined in DIN 51 825 are not sufficient for this application. Rather, the suitability of a lubricating grease for rolling bearings must have been proved, as is the case, for instance, with the FAG greases Arcanol L135V and L186V.

For applications where higher operating temperatures have to be accommodated, e.g. in screens for hot material, or where the bearings under certain conditions are quite considerably heated by the material to be screened it is a good idea to use special greases which are not impaired by high temperatures.

The required base oil viscosity depends on the operating conditions. A viscosity ratio of  $\kappa = \nu/\nu_1 \geq 2$  should be aimed at.  $\nu$  is the operating viscosity,  $\nu_1$  is the rated viscosity, see also FAG catalogue WL 41 520.

As the bearings are assembled, their cavities have to be packed with grease to capacity. To avoid excessive working of the lubricant, the housing cavities on both sides of the bearing must remain empty so that excessive grease can disperse into the housing cavities during the start-up period.

It is good practice to relubricate the bearings through the lubricating groove and the three lubricating holes in the outer ring which are a standard feature of all FAG special spherical roller bearings. In this way an even lubricant supply to both roller rows is ensured.

For applications where the bearings are relubricated laterally the distance between housing wall and bearing face on the grease supply side should be as small as possible so that the grease can get into the bearing quickly and without losses.

It is also good practice to relubricate vibrating machine bearings with relatively small quantities of grease at short intervals.

The table, fig. 15, shows the replenishment quantities in dependence on bearing size and speed. These grease quantities apply to a relubrication interval of 50 operating hours and normal operating temperatures.

If the bearings are continuously relubricated by means of a central lubricating system the grease quantity  $m_1$  required per hour and bearing can be determined by means of the following equation:

$$m_1 = 0.00004 \cdot D \cdot B$$

where

$$m_1 = \text{required grease quantity [g/h]}$$

$$D = \text{bearing O.D. [mm]}$$

$$B = \text{bearing width [mm]}$$

The labyrinth seals have to be relubricated once a week; if necessitated by unfavourable operating conditions (exposure to great amounts of dust, moisture, high operating temperature), more frequently. They should be packed with the same grease as the rolling bearings.

## 15: Replenishment quantities for spherical roller bearings in vibrating machines (relubrication interval: 50 operating hours)

| Bore reference number | Speed min <sup>-1</sup>                           |     |     |     |     |      |      |      |      |      |      |      |      |      |      |      |
|-----------------------|---|-----|-----|-----|-----|------|------|------|------|------|------|------|------|------|------|------|
|                       | 500   | 600 | 700 | 800 | 900 | 1000 | 1200 | 1400 | 1600 | 1800 | 2000 | 2200 | 2400 | 2600 | 2800 | 3000 |
| 08                    | Grease quantities in g for bearing series 223/233 |     |     |     |     |      |      |      |      |      |      |      |      |      |      |      |
| 09                    | approx. 5   |     |     |     |     |      |      |      |      |      |      |      |      |      |      |      |
| 10                    |   |     |     |     |     |      |      |      |      |      |      |      |      |      |      |      |
| 11                    |   |     |     |     |     |      |      |      |      |      |      |      |      |      |      |      |
| 12                    | ca. 5   |     |     |     |     |      |      |      |      |      |      |      |      |      |      |      |
| 13                    |   |     |     |     |     |      |      |      |      |      |      |      |      |      |      |      |
| 14                    |   |     |     |     |     |      |      |      |      |      |      |      |      |      |      |      |
| 15                    |   |     |     |     |     |      |      |      |      |      |      |      |      |      |      |      |
| 16                    |   |     |     |     |     |      |      |      |      |      |      |      |      |      |      |      |
| 17                    |   |     |     |     |     |      |      |      |      |      |      |      |      |      |      |      |
| 18                    |   |     |     |     |     |      |      |      |      |      |      |      |      |      |      |      |
| 19                    |   |     |     |     |     |      |      |      |      |      |      |      |      |      |      |      |
| 20                    |   |     |     |     |     |      |      |      |      |      |      |      |      |      |      |      |
| 22                    |   |     |     |     |     |      |      |      |      |      |      |      |      |      |      |      |
| 24                    |   |     |     |     |     |      |      |      |      |      |      |      |      |      |      |      |
| 26                    |   |     |     |     |     |      |      |      |      |      |      |      |      |      |      |      |
| 28                    |   |     |     |     |     |      |      |      |      |      |      |      |      |      |      |      |
| 30                    |   |     |     |     |     |      |      |      |      |      |      |      |      |      |      |      |
| 32                    |   |     |     |     |     |      |      |      |      |      |      |      |      |      |      |      |
| 34                    |   |     |     |     |     |      |      |      |      |      |      |      |      |      |      |      |
| 36                    |   |     |     |     |     |      |      |      |      |      |      |      |      |      |      |      |
| 38                    |   |     |     |     |     |      |      |      |      |      |      |      |      |      |      |      |
| 40                    |   |     |     |     |     |      |      |      |      |      |      |      |      |      |      |      |
| 44                    |   |     |     |     |     |      |      |      |      |      |      |      |      |      |      |      |
| 48                    |   |     |     |     |     |      |      |      |      |      |      |      |      |      |      |      |
| 52                    |   |     |     |     |     |      |      |      |      |      |      |      |      |      |      |      |
| 56                    |   |     |     |     |     |      |      |      |      |      |      |      |      |      |      |      |

### 4.2 Oil lubrication

Speeds above the range suitable for grease lubrication (i. e. speed index  $n \cdot d_m > 300\,000 \text{ min}^{-1} \cdot \text{mm}$ ) require oil lubrication. Lubrication with oil may also be required for applications where the bearings are exposed to external heating. Maintenance may be another reason for oil lubrication.

We recommend to lubricate the bearings either with mineral oils or with synthetic oils containing EP additives and

anti-corrosion additives, see also section 4.3. Good-quality multigrade oils may also be used.

The viscosity ratio  $\kappa = \nu/\nu_1$  ( $\nu$  = operating viscosity,  $\nu_1$  = rated viscosity) should be  $\geq 2$ .

#### 4.2.1 Oil sump lubrication (oil bath lubrication)

Oil sump lubrication is normally used up to a speed index of  $n \cdot d_m = 300\,000 \text{ min}^{-1} \cdot \text{mm}$ ; if the oil is changed

frequently, even up to  $n \cdot d_m = 500\,000 \text{ min}^{-1} \cdot \text{mm}$ . With this lubrication system the lubricant is taken to the rolling contact areas by existing gearwheels, by the imbalance mass or by the rolling elements themselves.

For this purpose the oil level in the plant, i.e. in the bearing housing, must be high enough for the gearwheels or imbalance masses to plunge into the oil during operation and churn it. When the bearing is at rest, the bottommost roller must be half immersed in oil, fig. 16.

# Lubrication

## Oil lubrication

### 16: Determination of the oil level with the bearing at rest

|  | Bore reference number | Bearing series 223 and 233 |     |
|--|-----------------------|----------------------------|-----|
|  |                       | a<br>mm                    | b   |
|  | 08                    | 31                         | 34  |
|  | 09                    | 35                         | 38  |
|  | 10                    | 39                         | 42  |
|  | 11                    | 42                         | 46  |
|  | 12                    | 46                         | 50  |
|  | 13                    | 50                         | 54  |
|  | 14                    | 54                         | 59  |
|  | 15                    | 58                         | 62  |
|  | 16                    | 62                         | 67  |
|  | 17                    | 66                         | 71  |
|  | 18                    | 69                         | 74  |
|  | 19                    | 72                         | 78  |
|  | 20                    | 78                         | 84  |
|  | 22                    | 86                         | 94  |
|  | 24                    | 93                         | 101 |
|  | 26                    | 100                        | 109 |
|  | 28                    | 107                        | 117 |
|  | 30                    | 115                        | 125 |
|  | 32                    | 122                        | 133 |
|  | 34                    | 129                        | 140 |
|  | 36                    | 137                        | 149 |
|  | 38                    | 144                        | 156 |
|  | 40                    | 152                        | 165 |
|  | 44                    | 168                        | 182 |
|  | 48                    | 182                        | 195 |
|  | 52                    | 196                        | 211 |
|  | 56                    | 212                        | 228 |

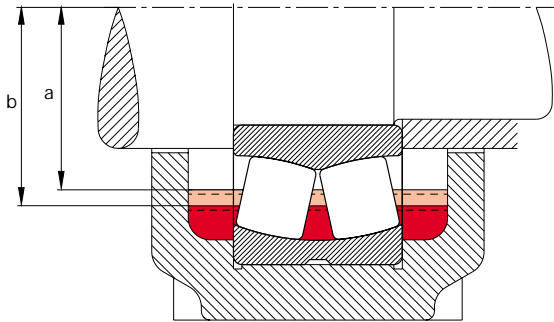

a is the normal oil level  
b is the minimum oil level

A sufficiently large quantity of oil increases the oil change interval. If the housing cavities are insufficient the shaft guard tube between the bearings is used as an additional reservoir. Otherwise, an extra oil tank will have to be provided.

The oil change interval depends on the contamination and the ageing condition of the oil. Fig. 17 shows recommended oil quantities and oil change intervals as a function of the bearing bore. For more details, see FAG Publ. No. WL 81 115/4 EA "Rolling Bearing Lubrication".

We recommend to inspect the oil regularly in order to determine the required oil change intervals more accurately based on the results of these inspections.

17: Oil quantities and oil change intervals as a function of the bearing bore

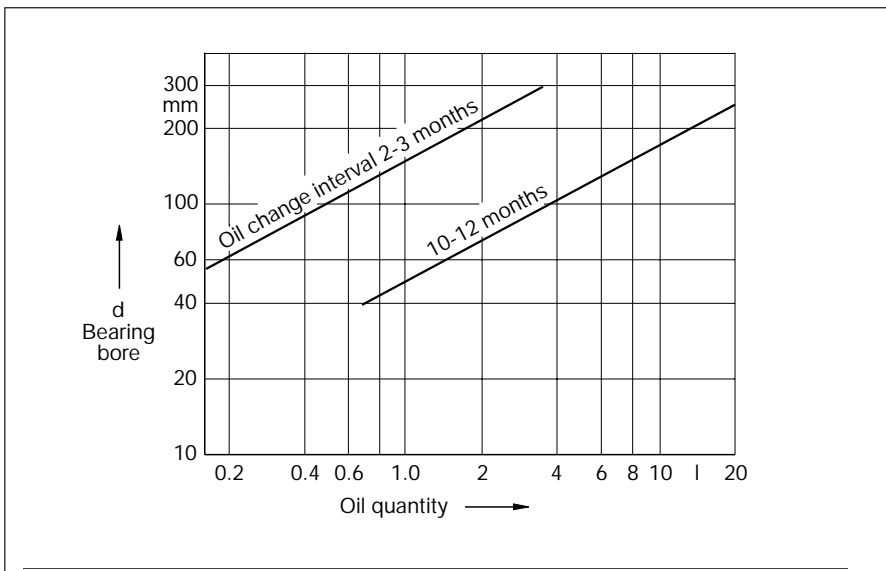

18: Minimum oil flow rates for spherical roller bearings of series 223 and 233 in vibrating machines

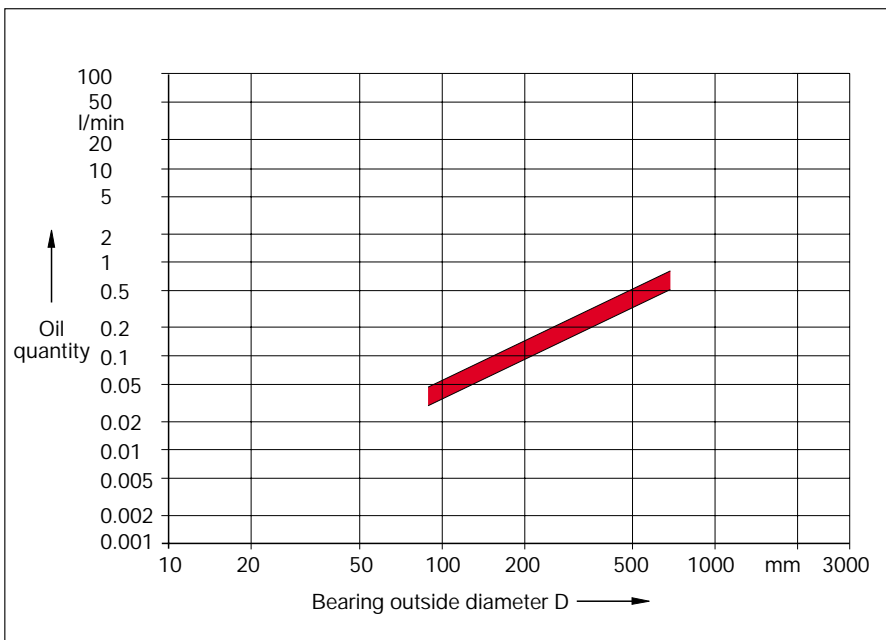

## 4.2.2 Oil circulation lubrication

Oil circulation lubrication has to be provided for applications where the speed index is higher than the admissible value indicated for oil bath lubrication or where less favourable conditions (large amounts of heat have to be dissipated, insufficient space in oil chambers) have to be accommodated. The oil should be fed to the bearing through the lubricating groove and the lubricating holes in the outer ring.

The diagram in fig. 18 shows the recommended, usual oil flow rates.

In order to prevent oil retention within the lubrication system the cross sections of the unpressurized return ducts must be adapted to the cross sections of the feed ducts (4 to 5 times as large).

With oil circulation lubrication, a filter for retaining wear particles and contaminants is a must to prevent bearing life reductions.

Analysing the results of regular oil inspections allows operators to adapt the oil change intervals more accurately to the prevailing operating conditions.

---

# Lubrication

## Recommended lubricants

### 4.3 Recommended lubricants

#### Greases for vibrating screen bearings

The quality of the FAG rolling bearing greases Arcanol is carefully monitored by 100 % inspection of every batch.

Greases for normal temperatures:

Arcanol L135V  
Arcanol L186V  
Arcanol L215 V

Grease for high temperatures:

Arcanol L195V

FAG cannot make any statements concerning batch variations, formulation changes or influences of production on greases that do not pass through our goods inwards inspection. However, FAG keeps a list of suitable commercial greases which is continuously updated. The currently valid list can be ordered from FAG under the telephone number (0 97 21) 91 38 83.

#### Oils for vibrating screen bearings

The additives of oils used for this application must be proved to be effective in rolling bearings. As a rule, both mineral and synthetic oils can be used, with the exception of silicone oils. Oils with viscosity index improvers are not recommendable. An up-to-date list of recommendable oils can be ordered from FAG under the telephone number (0 97 21) 91 38 83.

# FAG Special Spherical Roller Bearings for Vibrating Machines

with a cylindrical bore

Series 223E.T41A

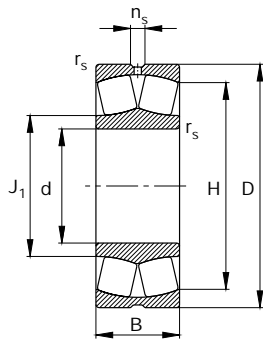

| Shaft | Dimensions |     |     |       |       |     |       | Load rating |                   | Limiting speed | Reference speed | Code         | Mass  |
|-------|------------|-----|-----|-------|-------|-----|-------|-------------|-------------------|----------------|-----------------|--------------|-------|
|       | d          | D   | B   | $r_s$ | $n_s$ | H   | $J_1$ | dyn. C      | stat. $C_0$       |                |                 |              |       |
|       | mm         |     |     |       |       |     |       | kN          | $\text{min}^{-1}$ |                |                 |              |       |
|       |            |     |     |       |       |     |       | FAG         | kg                |                |                 |              |       |
| 40    | 40         | 90  | 33  | 1.5   | 4.8   | 77  | 52    | 129         | 143               | 7500           | 7000            | 22308E.T41A  | 0.984 |
| 45    | 45         | 100 | 36  | 1.5   | 6.5   | 86  | 58    | 156         | 176               | 6700           | 6300            | 22309E.T41A  | 1.36  |
| 50    | 50         | 110 | 40  | 2     | 6.5   | 94  | 63    | 190         | 216               | 6000           | 6000            | 22310E.T41A  | 1.87  |
| 55    | 55         | 120 | 43  | 2     | 6.5   | 102 | 68    | 224         | 255               | 5600           | 5600            | 22311E.T41A  | 2.02  |
| 60    | 60         | 130 | 46  | 2.1   | 6.5   | 111 | 74    | 260         | 300               | 5000           | 5000            | 22312E.T41A  | 2.8   |
| 65    | 65         | 140 | 48  | 2.1   | 9.5   | 120 | 83    | 290         | 355               | 4800           | 4500            | 22313E.T41A  | 3.57  |
| 70    | 70         | 150 | 51  | 2.1   | 9.5   | 129 | 86    | 325         | 375               | 4500           | 4300            | 22314E.T41A  | 4.25  |
| 75    | 75         | 160 | 55  | 2.1   | 9.5   | 137 | 92    | 375         | 440               | 4300           | 3800            | 22315E.T41A  | 5.01  |
| 80    | 80         | 170 | 58  | 2.1   | 9.5   | 146 | 98    | 415         | 500               | 4300           | 3600            | 22316E.T41A  | 6.27  |
| 85    | 85         | 180 | 60  | 3     | 9.5   | 155 | 104   | 455         | 540               | 4000           | 3200            | 22317E.T41A  | 6.84  |
| 90    | 90         | 190 | 64  | 3     | 12.2  | 163 | 110   | 510         | 620               | 3600           | 3000            | 22318E.T41A  | 8.08  |
| 95    | 95         | 200 | 67  | 3     | 12.2  | 172 | 115   | 560         | 680               | 3000           | 2800            | 22319E.T41A  | 9.21  |
| 100   | 100        | 215 | 73  | 3     | 12.2  | 184 | 124   | 655         | 815               | 3000           | 2600            | 22320ED.T41A | 12    |
| 110   | 110        | 240 | 80  | 3     | 15    | 206 | 143   | 800         | 1060              | 2600           | 2200            | 22322ED.T41A | 17.4  |
| 120   | 120        | 260 | 86  | 3     | 15    | 224 | 150   | 900         | 1140              | 2600           | 2000            | 22324ED.T41A | 21    |
| 130   | 130        | 280 | 93  | 4     | 17.7  | 241 | 162   | 1040        | 1340              | 2400           | 1900            | 22326ED.T41A | 27.1  |
| 140   | 140        | 300 | 102 | 4     | 17.7  | 257 | 173   | 1220        | 1600              | 2200           | 1700            | 22328ED.T41A | 34    |
| 150   | 150        | 320 | 108 | 4     | 17.7  | 274 | 185   | 1370        | 1830              | 2000           | 1500            | 22330ED.T41A | 40.6  |

# FAG Special Spherical Roller Bearings for Vibrating Machines

with a cylindrical bore

Series 223A.MA.T41A  
Series 233A(S).MA.T41A

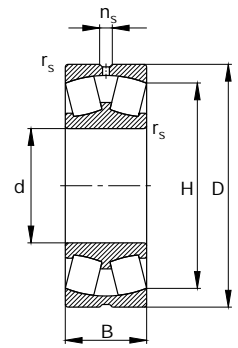

| Shaft      | Dimensions |     |     |       |       |     | Load rating |                   | Limiting speed | Reference speed | Code                  | Mass |
|------------|------------|-----|-----|-------|-------|-----|-------------|-------------------|----------------|-----------------|-----------------------|------|
|            | d          | D   | B   | $r_s$ | $n_s$ | H   | dyn. C      | stat. $C_0$       |                |                 |                       |      |
|            | mm         |     |     |       |       |     | kN          | $\text{min}^{-1}$ |                |                 |                       |      |
| <b>160</b> | 160        | 340 | 114 | 4     | 17.7  | 289 | 1430        | 1900              | 2000           | 1500            | <b>22332A.MA.T41A</b> | 52.7 |
| <b>170</b> | 170        | 360 | 120 | 4     | 17.7  | 305 | 1600        | 2120              | 1800           | 1400            | <b>22334A.MA.T41A</b> | 59.5 |
| <b>180</b> | 180        | 380 | 126 | 4     | 23.5  | 324 | 1760        | 2360              | 1500           | 1300            | <b>22336A.MA.T41A</b> | 72.2 |
| <b>190</b> | 190        | 400 | 132 | 5     | 23.5  | 339 | 1860        | 2500              | 1500           | 1200            | <b>22338A.MA.T41A</b> | 81   |
| <b>200</b> | 200        | 420 | 138 | 5     | 23.5  | 359 | 2080        | 2800              | 1400           | 1100            | <b>22340A.MA.T41A</b> | 93.5 |
| <b>220</b> | 220        | 460 | 145 | 5     | 23.5  | 392 | 2320        | 3350              | 1300           | 950             | <b>22344A.MA.T41A</b> | 120  |

| Shaft      | Dimensions |     |      |       |       |     | Load rating |                   | Limiting speed | Code                   | Mass |
|------------|------------|-----|------|-------|-------|-----|-------------|-------------------|----------------|------------------------|------|
|            | d          | D   | B    | $r_s$ | $n_s$ | H   | dyn. C      | stat. $C_0$       |                |                        |      |
|            | mm         |     |      |       |       |     | kN          | $\text{min}^{-1}$ |                |                        |      |
| <b>100</b> | 100        | 215 | 82.6 | 3     | 9.5   | 180 | 680         | 900               | 2800           | <b>23320AS.MA.T41A</b> | 15.3 |
| <b>110</b> | 110        | 240 | 92.1 | 3     | 12.2  | 201 | 830         | 1080              | 2600           | <b>23322AS.MA.T41A</b> | 21.1 |
| <b>120</b> | 120        | 260 | 106  | 3     | 12.2  | 216 | 1020        | 1430              | 2400           | <b>23324AS.MA.T41A</b> | 28.9 |
| <b>130</b> | 130        | 280 | 112  | 4     | 12.2  | 233 | 1160        | 1600              | 2200           | <b>23326AS.MA.T41A</b> | 35.3 |
| <b>140</b> | 140        | 300 | 118  | 4     | 12.2  | 250 | 1270        | 1800              | 2000           | <b>23328AS.MA.T41A</b> | 40.7 |
| <b>150</b> | 150        | 320 | 128  | 4     | 15    | 266 | 1500        | 2120              | 2000           | <b>23330A.MA.T41A</b>  | 49.8 |
| <b>160</b> | 160        | 340 | 136  | 4     | 17.7  | 282 | 1660        | 2320              | 2000           | <b>23332A.MA.T41A</b>  | 62.6 |
| <b>190</b> | 190        | 400 | 155  | 5     | 17.7  | 334 | 2200        | 3200              | 1400           | <b>23338A.MA.T41A</b>  | 97.1 |
| <b>200</b> | 200        | 420 | 165  | 5     | 17.7  | 351 | 2450        | 3600              | 1300           | <b>23340A.MA.T41A</b>  | 108  |

## FAG OEM und Handel Aktiengesellschaft

Postfach 1260  
D-97419 Schweinfurt  
Georg-Schäfer-Strasse 30  
D-97421 Schweinfurt  
Tel. +49 (0) 97 21 / 91 38 83  
Fax +49 (0) 97 21 / 91 39 58  
E-mail: ludwig\_w@fag.de  
[www.fag.de](http://www.fag.de)

Every care has been taken to ensure the correctness of the information contained in this publication but no liability can be accepted for any errors or omissions. We reserve the right to make changes in the interest of technical progress.  
© by FAG 2000. This publication or parts thereof may not be reproduced without our permission.